

WADA-SHOJI INC  
HEAD OFFICE / FACTORY

1662. ONI ZUCHOGUCHI . ONGA-CHO. ONGA-GUN  
FUKUOKA . 811-4341. JAPAN  
TEL: 093-293-5577  
FAX: 093-293-5566

PROJECT:

TITLE:

SEN°C \_ SINK

DATE:

2022/04/18

DRAWN BY:

Y . W A D A

CHEKED BY:

FAI NAL CHEKED BY:

SCALE:

No:

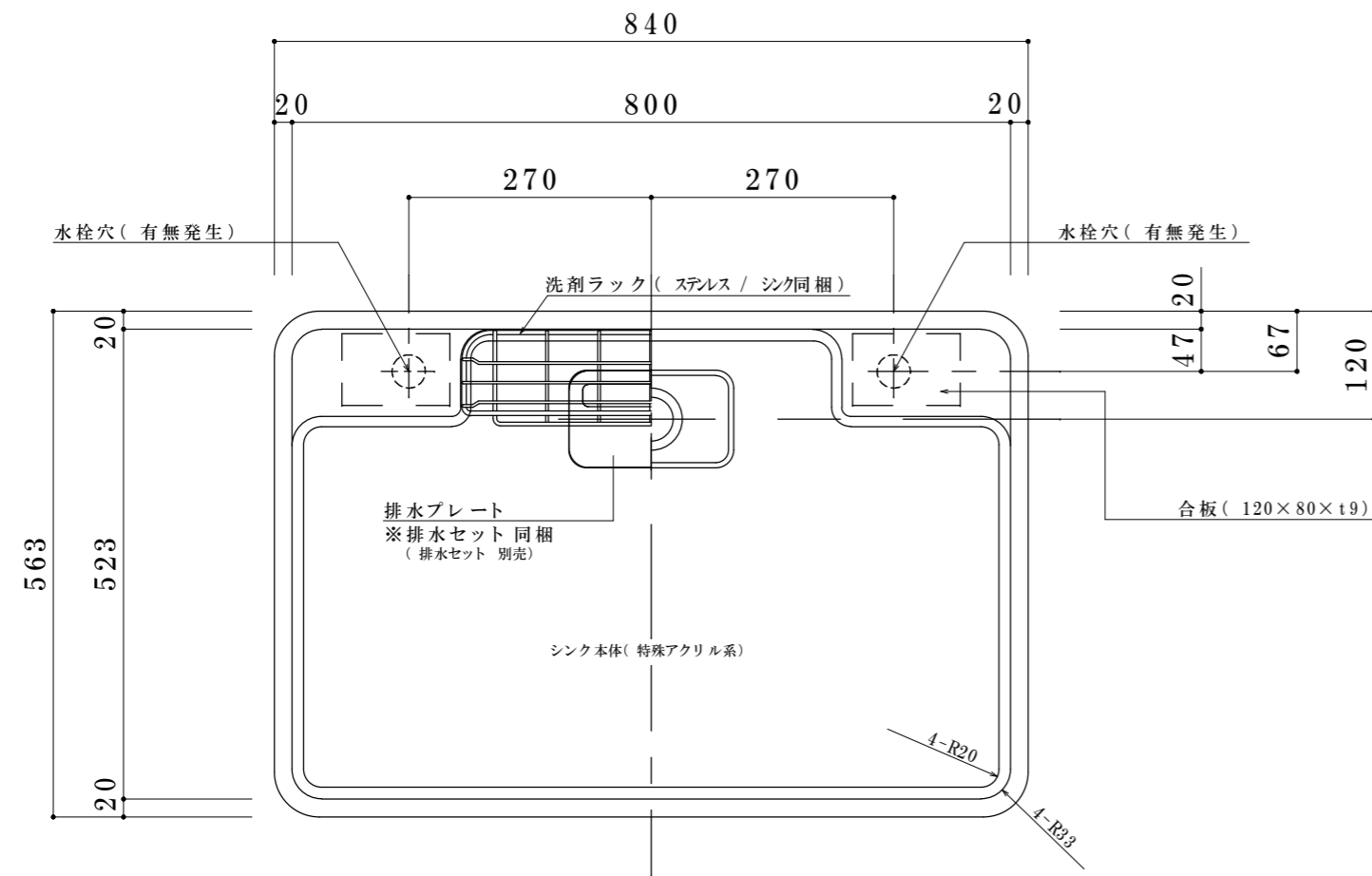

■注記

・シンク付属品および別売品の詳細については、各部品詳細図参照のこと。

■COLLAR

- ・ G \_ white ( グラーノ ホワイト )
- ・ C \_ beige ( カームベージュ )
- ・ C \_ gray ( カームグレー )
- ・ gray ( グレー )

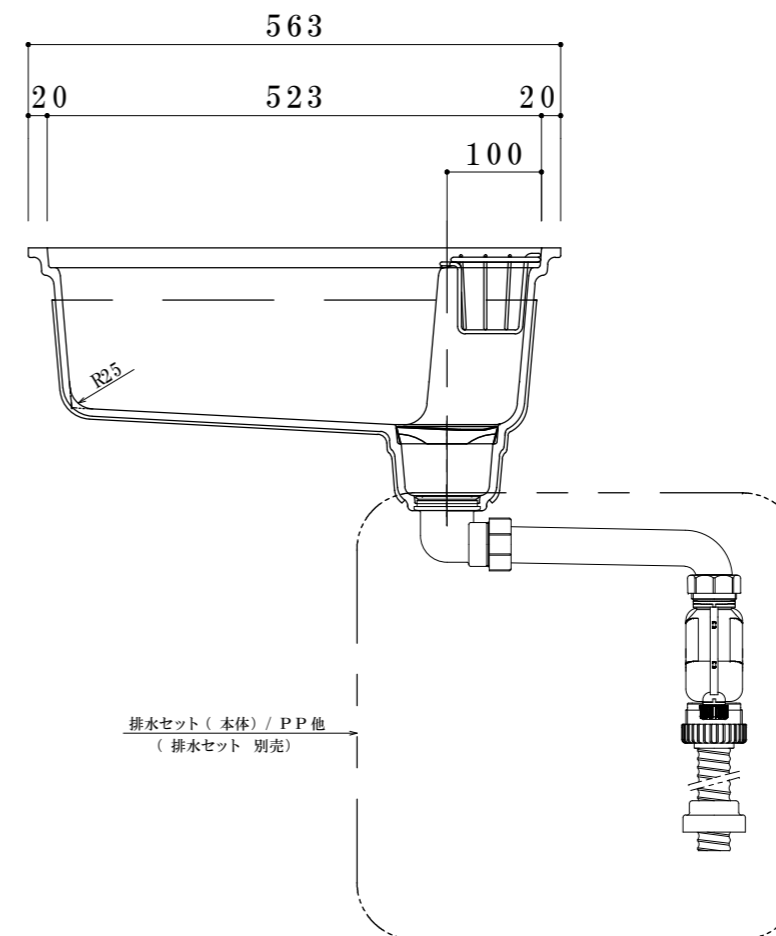
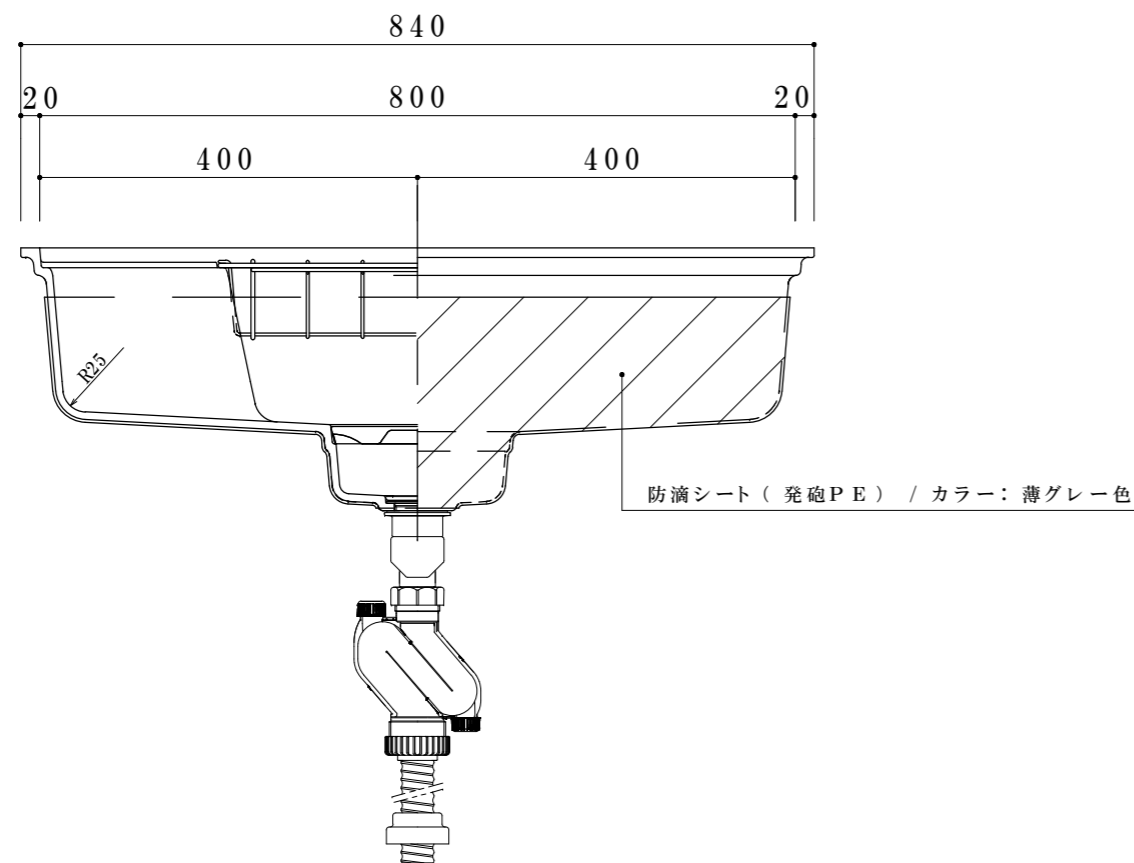

■ステンレス製アミカゴ(ステン枠)

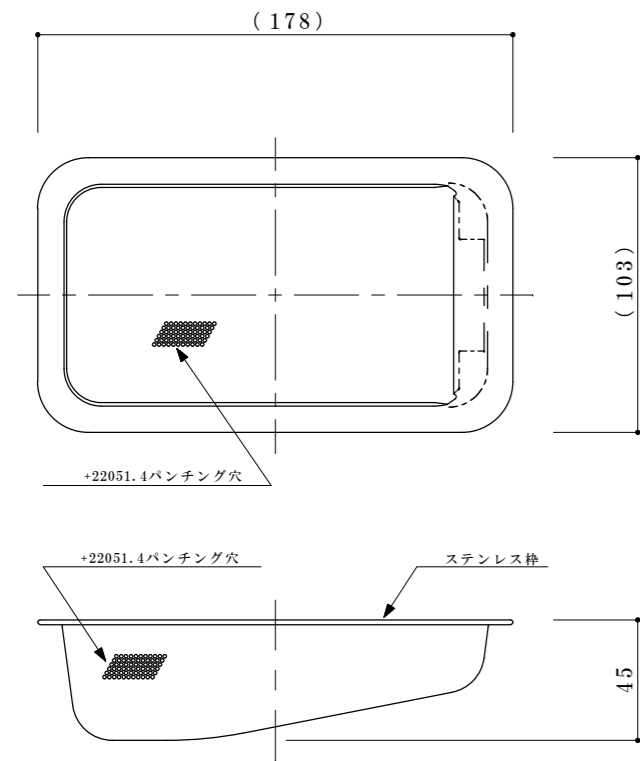

■排水プレート

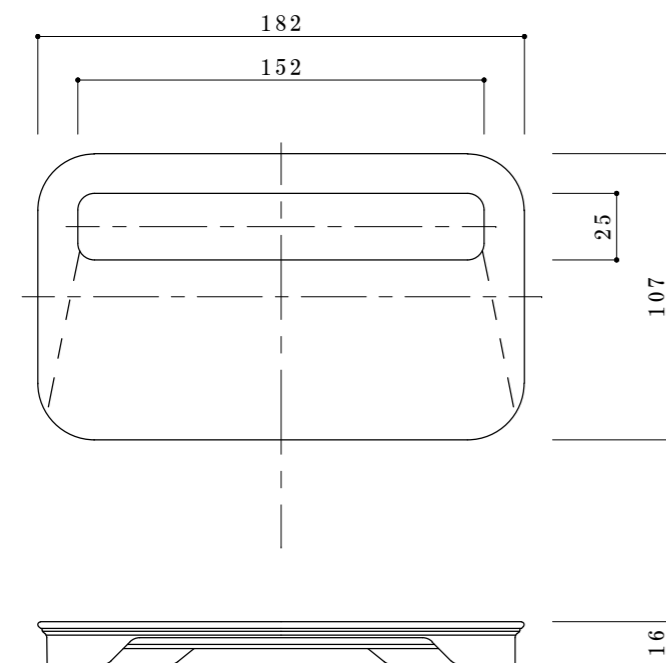

■排水トラップ

2022\_04\_18\_SEN°C\_WAT1SHAESA2

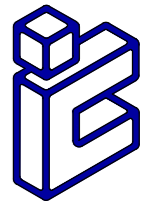
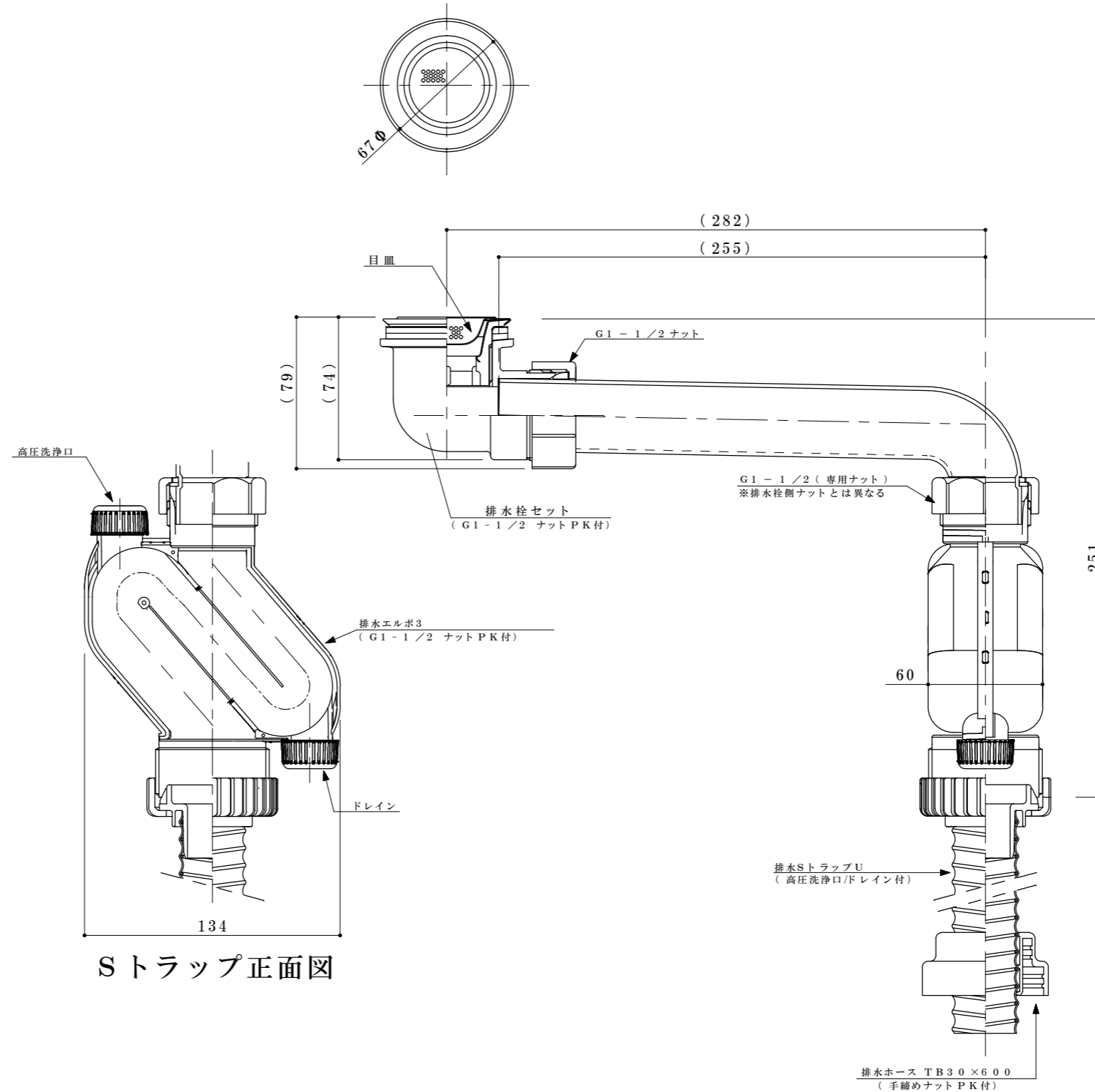

SEN°C

WADA-SHOJI INC  
 HEAD OFFICE / FACTORY  
 1662, ONI ZUCHOGUCHI, ONGA-CHO, ONGA-GUN  
 FUKUOKA . 811-4341. JAPAN  
 TEL: 093-293-5577  
 FAX: 093-293-5566

PROJECT:

TITLE:

SEN°C\_SINK 排水セット

DATE:  
 2022 / 04 / 18

DRAWN BY:  
 Y. WADA

CHEKED BY:

FAI NAL CHEKED BY:

SCALE:

No:

**止水プレート (オプション品)**

2020\_01\_29\_SEN'C\_WAJUG404BC1

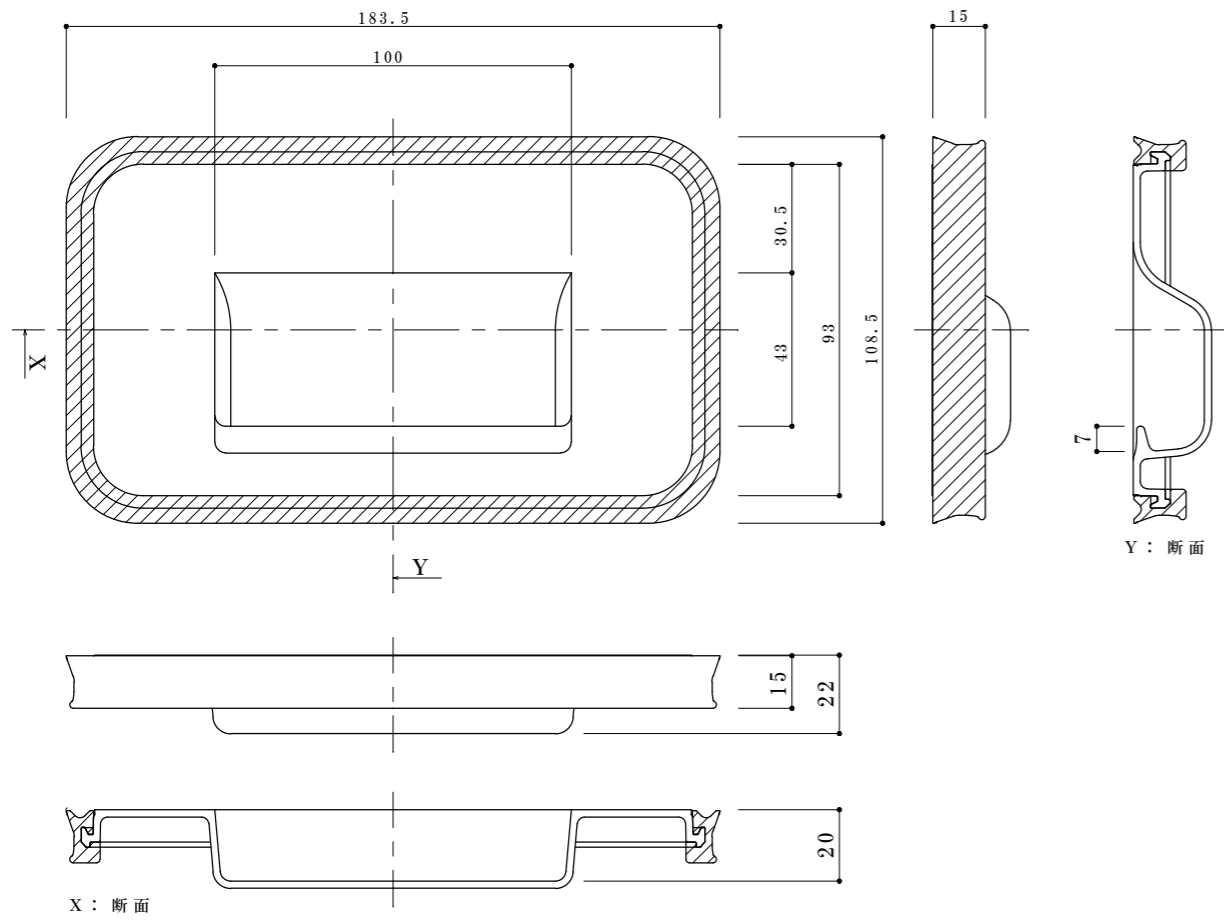

**水切りラック【大】 (オプション品)**

2020\_01\_29\_SEN'C\_WAJUG46SC4C

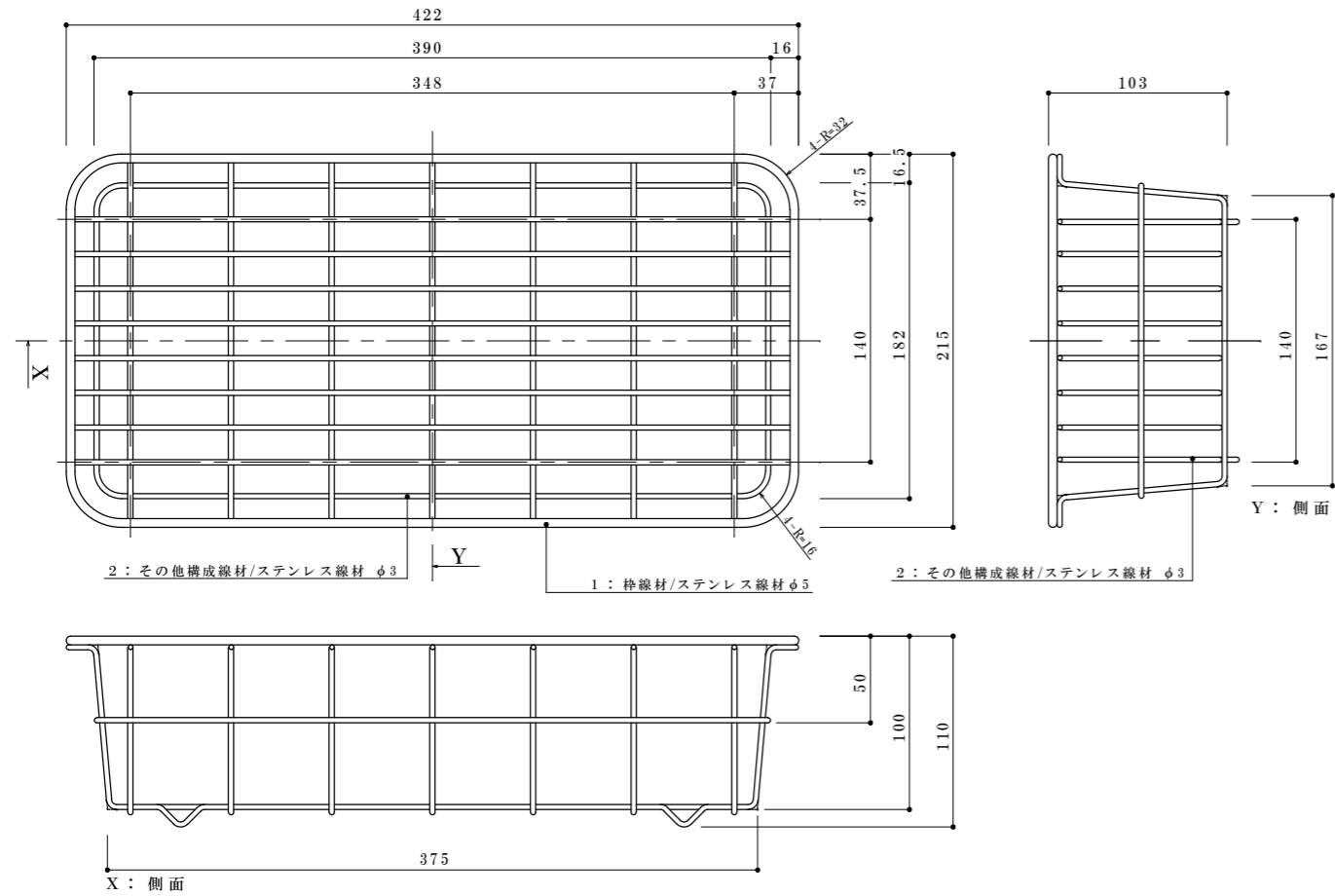

**水切りラック【小】 (オプション品)**

2020\_01\_29\_SEN'C\_WAJUG48SC1S

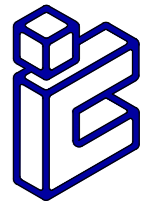
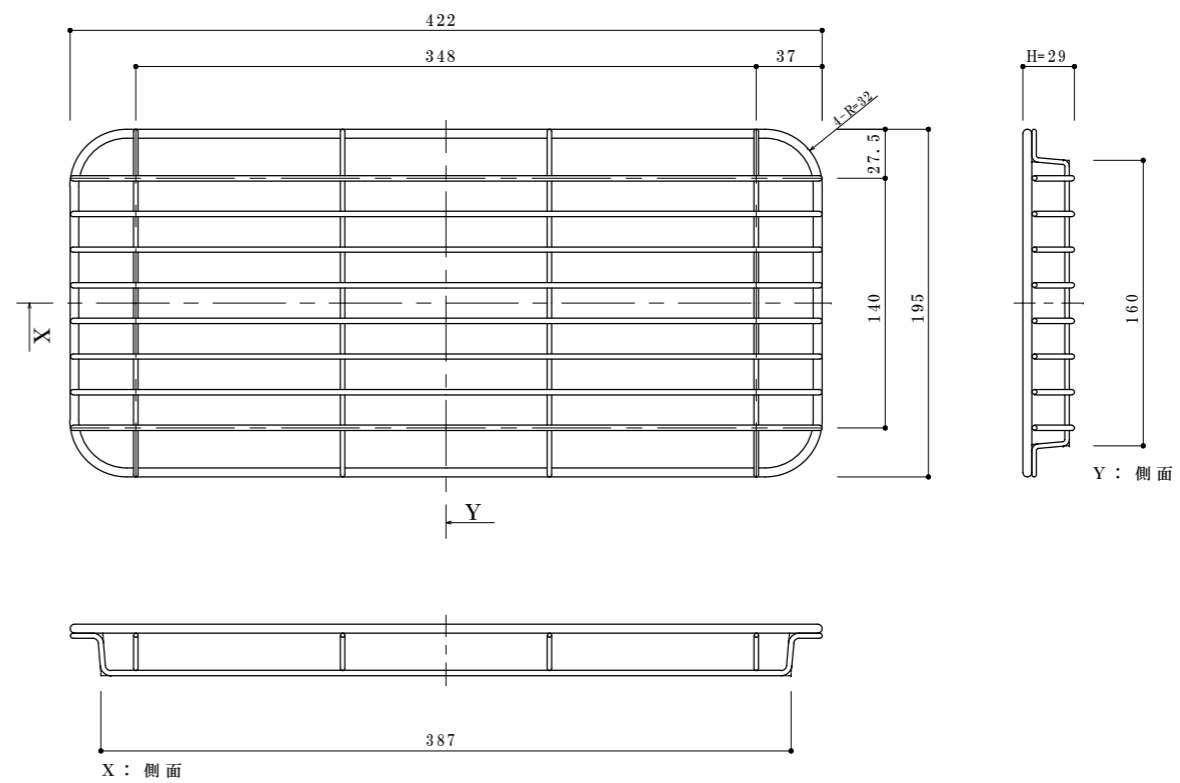

**SEN'C**

WADA-SHOJI INC  
 HEAD OFFICE / FACTORY  
 1662, ONI ZUCHOGUCHI, ONGA-CHO, ONGA-GUN  
 FUKUOKA, 811-4341, JAPAN  
 TEL: 093-293-5577  
 FAX: 093-293-5566

PROJECT:

TITLE:

OPTION  
 (SEN'C\_SINK)

DATE:  
 2020 / 01 / 29

DRAWN BY:

Y. WADA

CHEKED BY:

FINAL CHEKED BY:

SCALE:

No: